

UNATTENDED

60 kW TO 1.25 MW

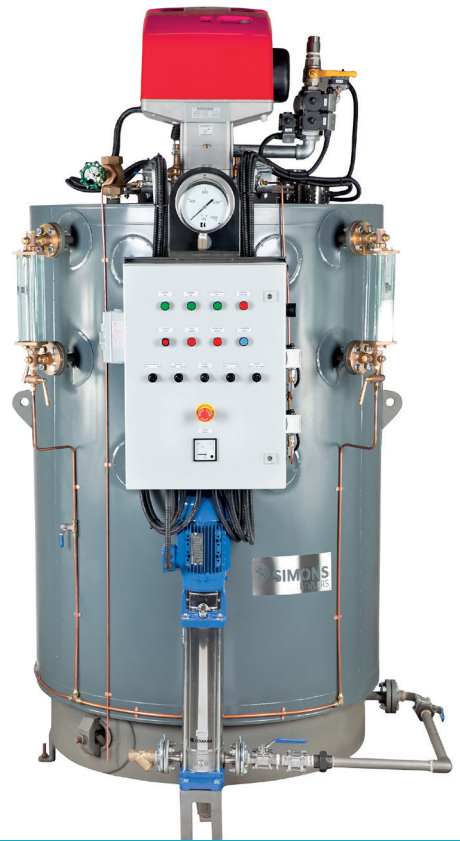

GAS - DIESEL STEAM BOILER

60 kW - 1.25 MW

A highly efficient water-tube steam boiler with features and system options, manufactured to meet the clients specification. With steam capacities ranging from 92 to 1,956 kg/hr, the boiler is available in natural gas, LPG or diesel firing configurations, or combination of two fuels.

FEATURES

- **Operating Pressure** - Boilers are supplied as standard for 950kPa operating pressure.
- **Efficiency** - The 3 pass, natural circulation water wall design, provide a guaranteed minimum 80% operating efficiency
- **No Boiler Ticket Required** - safety features exceed code minimum requirements, with boilers greater than 500kW being fitted with system diagnostics, and self check functions. CLASSIFIED FOR UNATTENDED OPERATION.
- **Radiated Heat** - High quality thermal insulation is fitted to the boilers, providing drastic reductions in radiated heat and increased energy efficiency
- **Warranty:** All boilers carry a 12 months warranty on controls, peripheral equipment and shell, providing the boiler is operated and maintained within relevant Standards, including water treatment.

ADVANTAGES

- Low capital cost
- Fully welded tubes
- 3 pass design
- Low heat emissions
- Minimal space requirement
- Quality fitout components
- Easy to operate
- Parts readily available

APPLICATIONS

- Hospital Sterilizers
- Autoclaves
- Laundries
- Dry cleaners
- Industrial process heating
- Food processors
- Apiarists
- Pharmaceutical Industry
- Rubber Processors

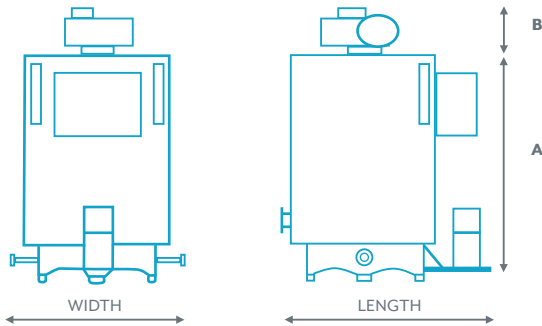

DIMENSIONS DRAWING

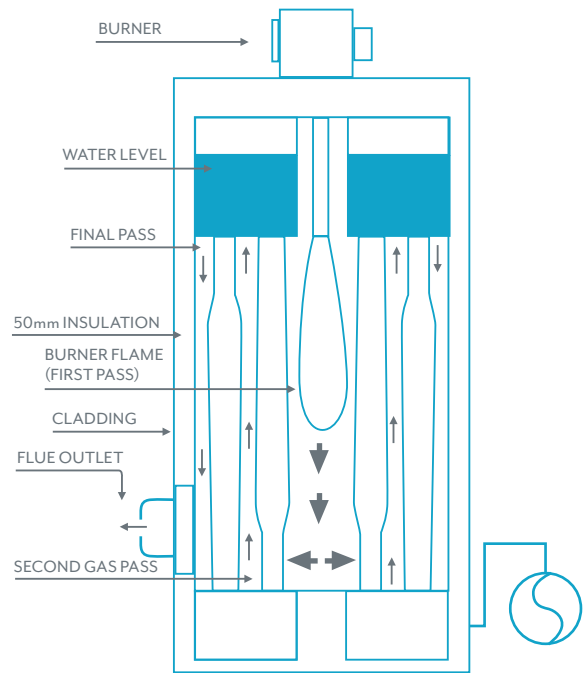

SCHEMATIC DIAGRAM

MODEL NUMBER	BOILER HP	BOILER KW	OUTPUT lb/hr	OUTPUT kg/hr	INPUT mj/hr	DIAM mm	WIDTH mm	LENGTH mm	HEIGHT A mm	HEIGHT B mm	SHIPPING WEIGHT Kg	FLUE SIZE mm	STEAM OUTLET mm	POWER AMPS	WATER INLET mm	SAFETY VENTS mm	B/DOWN LINES mm	FLOODED VOLUME
SWT 60	6	60	212	96	270	560	850	950	1532	300	800	150	20	10	20	20	25	183
SWT 100	10	100	352	160	450	560	850	950	1632	400	1000	150	20	10	20	20	25	193
SWT 150	15	150	528	240	675	830	1200	1400	1630	400	1300	200	20	10	25	20	40	408
SWT 200	20	200	704	320	900	830	1200	1400	1730	400	1400	200	25	10	25	20	40	423
SWT 250	25	250	880	400	1125	830	1200	1400	2130	450	1900	200	32	10	25	20	40	483
SWT 300	30	300	1056	480	1350	830	1200	1400	2130	450	1900	200	32	10	25	20	40	483
SWT 350	35	350	1232	560	1575	1166	1550	1650	2019	500	2500	250	40	15	25	20	40	845
SWT 400	40	400	1408	640	1800	1166	1550	1650	2019	500	2500	250	40	15	25	20	40	845
SWT 500	50	500	1760	800	2250	1166	1550	1650	2120	500	2700	250	40	15	25	20	40	867
SWT 600	60	600	2112	960	2700	1300	1550	1650	2140	650	2750	300	50	15	25	25	40	953 L
SWT 750	75	750	2640	1200	3375	1300	1550	1650	2410	650	3200	300	50	15	25	32	40	1068 L
SWT 1000	100	1000	3520	1600	4500	1400	1650	1800	2340	750	4200	300	65	20	25	32	40	1296 L
SWT 1250	125	1250	4400	2000	5471	1500	1800	1900	2600	1100	4400	300	65	20	25	32	40	1768 L

* Output is F&A 100°C. Specifications subject to change with out notice. Warranty conditional on verified maintenance

Australian family owned Company since 1932

Sold in over 30 countries around the world



DISTRIBUTED BY

SYDNEY Head Office

Unit 1, 33 Maddox Street
 Alexandria NSW 2015
 Australia
 Phone: 61 2 8338 8660
 Fax: 61 2 8338 8661
 Email: info@simonsboiler.com.au

MELBOURNE

34 Strong Avenue
 Thomastown VIC 3074
 Australia
 Phone: 61 3 9462 6700
 Fax: 61 3 9462 6711